



MLT 625-75 H



MLT 625-75 H	
Lifting	
Max. capacity	2500 kg
Max. lifting height	5.90 m
Break-out force with bucket (ISO 8313)	4205 daN
Unladen time	
Lifting	7.3 s
Lowering	4.95 s
Extension	5.2 s
Retraction	3.7 s
Crowd	3.2 s
Dump	3.2 s
Tyres	12.0-18 12 PR
Service brake	hydraulic oil immersed multi-disc braking
Engine	
Type	KUBOTA STAGE III B / FINAL TIER 4
Type	V3307-DI-T-E4B
Cubic capacity	4 cylinders - 3331 cm ³
Power	75 HP/55.4 kW Turbo
Max. torque	265 Nm
Injection	direct
Cooling	water
Laden drawbar pull	3240 daN
Transmission	
Reversing shift	hydrostatic
Number of gears (forward/reverse)	electro-hydraulic
Max. travel speed	2/2
(may vary according to applicable regulations)	30 kph
Steering mode	4 wheel steer - 3 Steering Modes
Controls	
	JSM® Joystick multi-fonction
	Load Limiter Cut off system - EN15000 Norm
Hydraulics	
Pump	gear type with priority valve 90 l/min - 235 bar
Capacities	
Cooling system	12 l
Engine oil	11.2 l
Hydraulic oil	115 l
Fuel	63 l
Unladen weight (with forks)	4932 kg
Dimensions	
C. Front wheel centre to carriage	0.99 m
B. Wheelbase	2.30 m
I. Rear wheel centre to rear face	0.60 m
D. Overall length to carriage	3.89 m
G. Ground clearance	0.38 m
J. Overall width of cab	0.79 m
F. Inside tyre width	1.50 m
W. Overall width	1.81 m
U1. Overall height	2.00 m
Standard forks (length x width x thickness)	1200 x 125 x 45 mm
Turning radius (over tyres)	3.31 m
Noise and vibration	
Noise at driving position (LpA)	76 dB
Environmental noise (LwA)	104 dB
Vibration to whole hand/arm	<2.50 m/s ²

Rough terrain load chart standard EN1459 B

Machine on tyres with forks

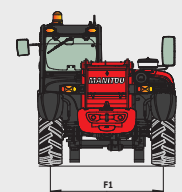
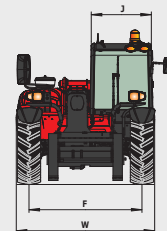
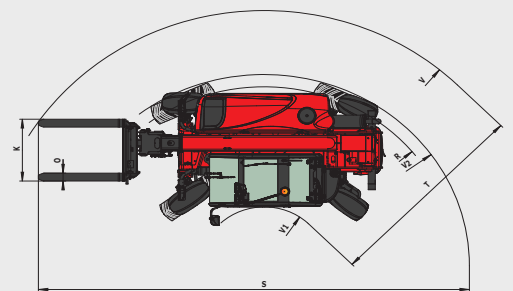
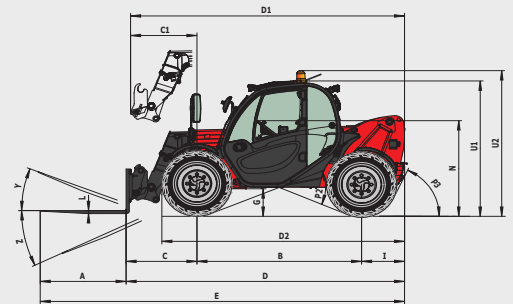
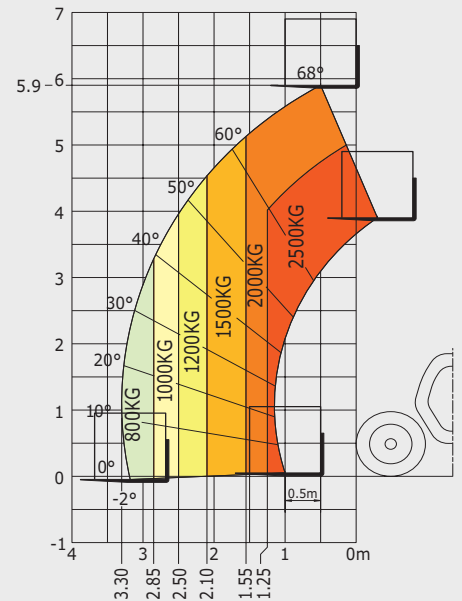

mm									
A	1200	D2	3393	K	1015	S	6531	W	1814
B	2300	E	5094	L	45	T	3475	Y	12°
C	991	F	1500	N	1398	U1	2000	Z	117°
C1	928	F1	1500	O	125	U2	2167		
D	3894	G	378	P2	45°	V	4240		
D1	3831	I	603	P3	65°	V1	765		
		J	797	R	3033	V2	3310		

This brochure describes versions and configuration options for MANITOU products which may be fitted with different equipment. The equipment described in this brochure may be standard, optional or not available depending on version. MANITOU reserves the right to change the specifications shown and described at any time and without prior warning. The manufacturer is not liable for the specifications given. For more information, contact your MANITOU dealer. Non-contractual document. Product descriptions may differ from actual products. List of specifications is not comprehensive. The logos and visual identity of the company are the property of MANITOU and may not be used without authorisation. All rights reserved. The photos and diagrams contained in this brochure are provided for information only.

