

MHT 10230

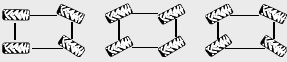

MHT 10230	
Lifting	
Max. capacity with forks at 900 mm	23 000 kg
Max. lifting height	9.65 m
Max. Outreach	5.8002 m
Tyres	18.00 R 25
Frame levelling	+/- 10°
Braking	
Service brake	Oil bath multiple-disc brakes hydraulically assisted on both axles
Parking brake	Automatic Negative Parking brake
Engine	
MERCEDES	
Type	OM 934 LA. E4-3 (Stage IV / Tier IV final)
Displacement	4 cylinders 5.1 liters
Power	176 HP / 129 kW
Max. torque	750 Nm / 1200-1600 rpm
Batteries	24 V - 2X12 V - 120 Ah - 850 A
Laden drawbar pull	18 500 daN
Gradability	34%
Transmission	
hydrostatic	
Reversing shift	electrohydraulic control
Number of gears (forward / reverse)	2/2
Steering mode	4 wheel steer - 3 steering Modes 
Max. travel speed (may vary according to applicable regulations)	25 kph
Axles	OMCI
Controls	
JSM® Joystick multi-fonction	
Hydraulics	
Load sensing Pump	205 l/min - 350 bar
Capacities	
Urea	63 l
Hydraulic oil	290 l
Fuel	315 l
Unladen weight (with forks)	29 300 kg
Dimensions	
Overall width	2.85 m
Overall height	3.05 m
Overall length to carriage	6.99 m
Ground clearance	0.49 m
Turning radius (over tyres)	5.40 m
Standard forks (length x width x thickness)	1800 x 200 x 110 mm
Safety	
Load state monitoring system (crane norms) attachment recognition system (E-Reco) cab ROPS FOPS level II	
Noise and vibration	
Noise at driving position (LpA)	80 dB
Environmental noise (LwA)	107 dB
Vibration to whole hand / arm	<2.5 m/s ²



MHT 10230



Machine on tyres with forks
CDG 900 mm

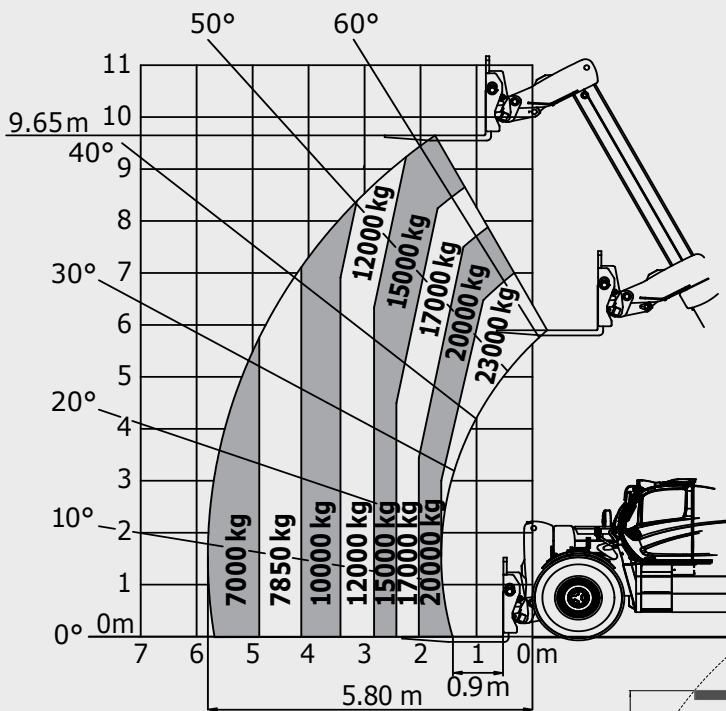

mm	MHT 10230
A	1800
B	3900
C	1350
C1	1195
D	6997
D1	6845
E	8797
F	2339
G	580
G1	490
G2	580
H	10°
H1	10°
I	1750
J	928

mm	MHT 10230
K	2000
L	110
M	2370
O	200
P2	16°
P3	32°
R	4945
S	10200
T	4400
U2	3055
V	6650
V1	2250
V2	5400
W	2850
Y	12°
Z	105°

