



YANMAR

COMPACT WHEELED EXCAVATOR

B95W



Operating weight	9 100 - 9 500 kg
Dig depth	4 080 mm
Engine power	74,4 kW (101 HP)
Bucket capacity	87 - 348 l
Digging force (bucket)	42,6 kN
Digging force (arm)	53,2 kN
Reach	7,6 - 8,1 m



DIMENSIONS

DIMENSIONS TPA, CIRCULAR, MONOBLOC BOOMS

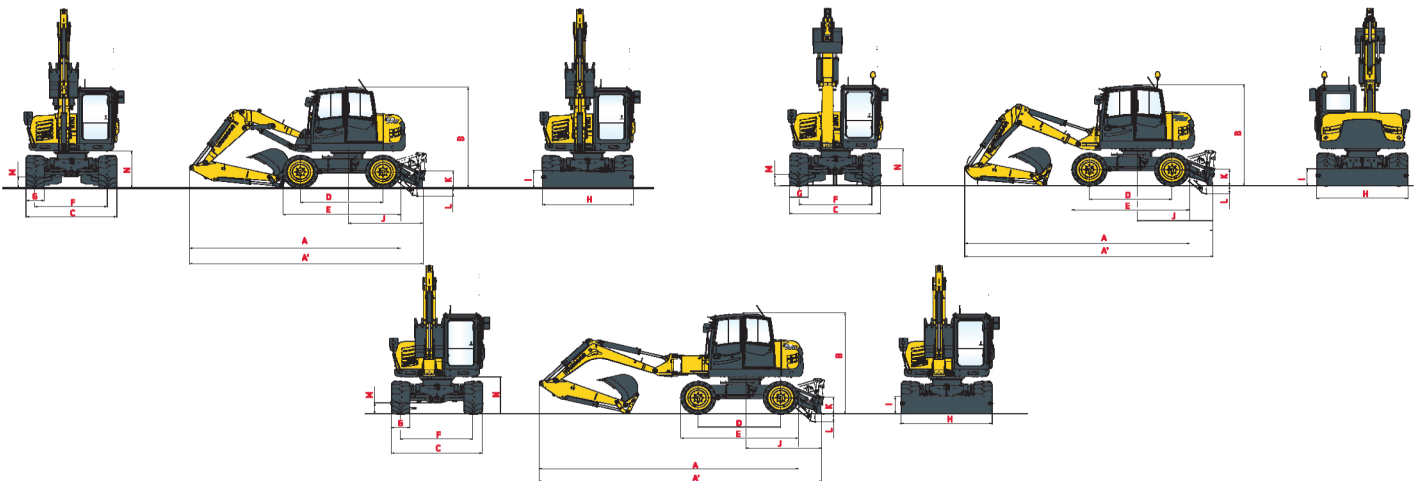

	TPA Boom	Circular Boom	Monobloc Boom		TPA Boom	Circular Boom	Monobloc Boom
A Overall length	5 700 mm	6 070 mm	7 000 mm	H Overall blade width	2 460 mm	2 460 mm	2 460 mm
A' Overall length with blade at the back	6 320 mm	6 700 mm	7 630 mm	I Overall blade height	500 mm	500 mm	500 mm
B Overall height	2 900 mm	2 900 mm	2 900 mm	J Blade distance	2 030 mm	2 030 mm	2 030 mm
C Overall width	2 460 mm	2 460 mm	2 460 mm	K Max. blade height above the ground	485 mm	485 mm	485 mm
D Wheel base	2 240 mm	2 240 mm	2 240 mm	L Max. blade depth	230 mm	230 mm	230 mm
E Undercarriage length	3 180 mm	3 180 mm	3 180 mm	M Minimum ground clearance	320 mm	320 mm	320 mm
F Lane	1 960 mm	1 960 mm	1 960 mm	N Ground clearance under counterweight	1 060 mm	1 060 mm	1 060 mm
G Tire width	496 mm	496 mm	496 mm				

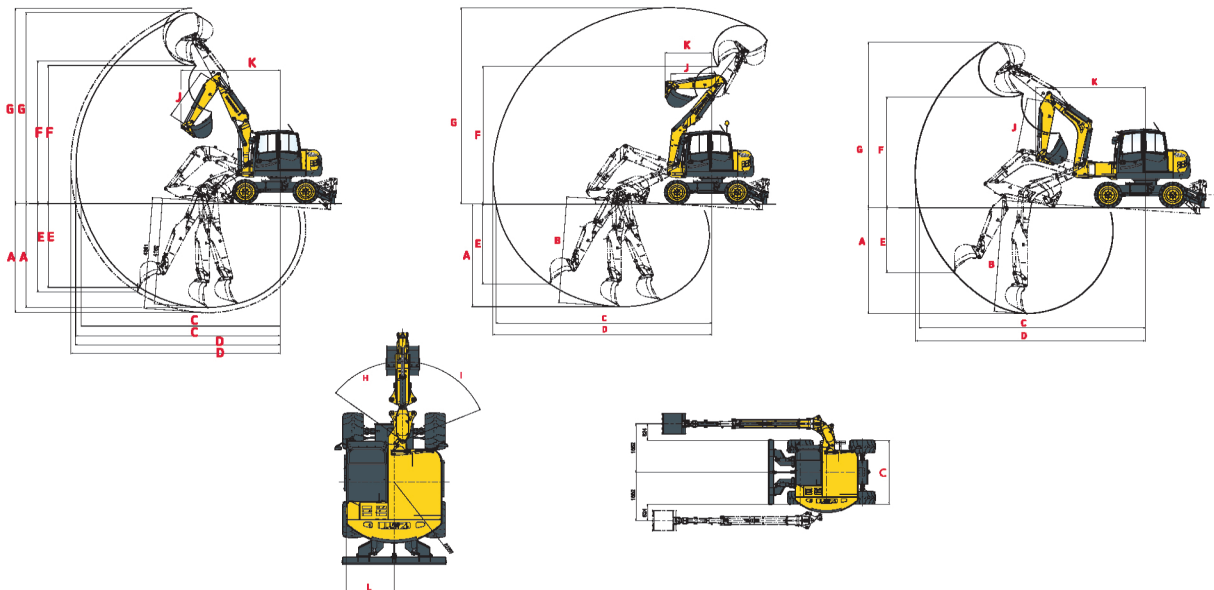

	TPA Boom	Circular Boom	Monobloc Boom		TPA Boom	Circular Boom	Monobloc Boom
A Max. digging depth - Blade lifted	4 100 / *4 300 mm	4 030 mm	3 890 mm	G Max. cutting height	7 500 / *7 660 mm	7 700 mm	6 070 mm
B Max. digging depth - Blade lowered	4 160 / *4 360 mm	4 160 mm	4 080 mm	H Boom swinging base to left	53°	53°	53°
C Max. digging reach on ground	7 370 / *7 550 mm	7 990 mm	7 820 mm	I Boom swinging base to right	67°	67°	67°
D Max. digging reach	7 570 / *7 740 mm	8 100 mm	7 960 mm	J Arm length	2 000 / *2 200 mm	1 650 mm	2 000 mm
E Max vertical wall	3 300 / *3 470 mm	3 140 mm	2 980 mm	K Front turning radius	3 670 mm	1 740 mm	3 790 mm
F Max. dumping height	5 410 / *5 580 mm	5 400 mm	4 060 mm	L Rear turning radius	1 550 mm	1 550 mm	1 550 mm

*TPA Boom with dipperstick 2 350 mm



LIFTING CAPACITIES



Blade down



Blade up



Tipping load,
rating over front



Tipping load,
rating over side 90°

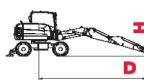

		TPA BOOM with dipperstick 2200 mm									
		D									
		3 m		4 m		5 m		6 m		Max.	
H											
		3,0 m		--	--	2,4	2,0	1,8	1,7	1,4	1,1
		--	--	2,1	1,9	1,5	1,6	0,9	1,0	0,8	0,8
1,5 m		4,2	3,5	2,6	2,3	1,6	1,6	1,5	1,0	1,3	0,8
		3,1	3,3	2,1	2,2	1,5	1,6	0,9	1,0	0,7	0,8
0,0 m		4,5	2,8	2,8	1,8	2,1	1,3	1,6	1,0	1,2	0,8
		2,5	2,6	1,6	1,7	1,2	1,2	0,9	0,9	0,7	0,8
-1,0 m		4,8	2,7	3	1,8	2,2	1,3	1,3	1	1,1	1,1
		2,5	2,6	1,6	1,7	1,2	1,2	0,9	0,9	0,8	0,9



		Monobloc offset boom									
		D									
		3 m		4 m		5 m		6 m		Max.	
H											
		3,0 m		--	--	--	--	--	--	1,7	1,1
		--	--	--	--	--	--	0,9	1,0	0,7	0,8
1,5 m		--	--	4,4	1,9	3,0	1,3	2,3	1,0	1,8	0,8
		--	--	1,6	1,8	1,1	1,2	0,9	0,9	0,7	0,7
0,0 m		--	--	5,3	1,7	3,2	1,3	2,3	0,9	1,7	0,8
		--	--	1,4	1,5	1,1	1,2	0,8	0,9	0,7	0,6
-1,0 m		--	2,4	4,4	1,6	2,8	1,2	1,9	0,9	1,6	0,8
		2,2	2,3	1,4	1,5	1,1	1,1	0,8	0,9	0,8	0,8

All values in tons (t) were determined acc. to ISO 10567 and include a stability factor of 1.33 or 87% of the hydraulic lifting capacity. All values were determined with load hook. If a bucket is attached, the difference weights bucket minus load hook must be deducted from the permissible payloads. When used for load hook applications, excavators must be equipped with hose-rupture valves and overload warning device in compliance with EN 474-5. Working equipment: Two-piece articulated boom, twin tires, dipperstick 2000 mm.



SPECIFICATIONS

[WEIGHT]

Operating weight (monobloc, TPA boom, circular boom) acc. to ISO 6016.	9 100 - 9 300 - 9 500 kg
Tread width.	1 960 mm
Wheelbase.	2 240 mm
Ground clearance below cardan shaft.	440 mm
Turning radius.	6 700 mm
Uppercarriage tailswing.	1 550 mm
Uppercarriage frontswing (monobloc, TPA, circular boom).	2 960 mm
Working envelope 180°.	4 510 mm
Working envelope 360° (monobloc, TPA, circular boom).	6 090 - 5 920 - 3 340 mm

[ENGINE]

Manufacturer, model.	Deutz, TCD3.6 L4
Type.	4-cylinder Turbo diesel engine with intercooler - EU Stage IV / TIER 4 final
Combustion.	4-stroke cycle, Common Rail injection
Displacement.	3 600 cm ³
Net power rating at 2000 rpm (ISO 9249).	74,4 kW (101 HP)
Torque.	410 Nm at 1 600 rpm
Cooling system.	Water

[HYDRAULIC SYSTEM]

Travel hydraulics: Closed circuit, independent from working hydraulics.	
Pump capacity, max.	112 l/min
Working pressure, max.	420 bar
Working hydraulics: Axial-piston variable displacement pump with load sensing, coupled with a load independent flow sharing (LUDV). Simultaneous, independent control of all movements. Sensitive maneuvers irrespective of loads.	
Max. pump capacity.	max. 142 l/min
Working pressure, max.	280 bar
The thermostatically controlled oil circuit ensures that the oil temperature is promptly reached and avoids overheating. Hydraulically driven fan with reversing function. Return filter installed in oil tank allows for eco-friendly replacement of filter elements.	
Triple gear pump for all positioning, swing movements and hydrostatic fan.	
Pump capacity, max.	38 + 38 + 38 l/min
Working pressure, max.	250 bar
Control circuit for work attachments, proportionally operated.	
Pump capacity, adjustable.	0 - 120 l/min
Working pressure, max.	280 bar
Two servo-assisted joystick controls (ISO) for excavator operations.	

[TRANSMISSION]

Hydrostatic travel drive in closed circuit with automatic adjustment of drawbar pull and speed irrespective of the working hydraulics.			
4-wheel drive from reduction gear on front axle via cardan shaft to rear axle. Infinitely variable speed control forward and reverse.			
2 speed ranges:	"Low" 0-6 km/h	4 speed ranges (high-speed version optional):	"Low" 0-5 / 0-15 km/h
	"High" 0-20 km/h		"High" 0-11 / 0-36 km/h

EQUIPMENT

[STANDARD EQUIPMENT]

CABINE

Spacious, sound-insulated full-vision steel cab (ROPS certified). Sliding window in cab door.
Safety glass windows, thermo windows tinted in green. Skylight thermos window, bronze tinted.
Panoramic rear window.
Front window supported by pneumatic springs, lockable for ventilation and slidable under cab roof. Windshield washer system. Storage compartment.
Preparation for radio installation. Left-hand outside rear-view mirror.
Cab heating with windshield defroster through coolant heat exchanger with continuous fan. Fresh air and recirculating air filters.
Rearview camera.
Operator's seat MSG 85 (comfort version), hydraulic damping, extra-high backrest, tilt-adjustable armrests, longitudinal-horizontal suspension, mechanical lumbar support. Lap belt.
Instrument panel on the right hand side of the operator's seat with visual & acoustic warning device, hour-meter and safety module.
Working floodlights Halogen H-3.
Sound power level (LWA) 100 dB (A).
Sound pressure level (LpA) 72 dB (A).
Sound level values measured in compliance with Directive 2000/14/EC and EN474.
Effective values of acceleration for whole body less than 0.5 m/s ² .
Effective values of acceleration for hand-arm less than 2.5 m/s ² .
Vibration values in compliance with Directive 2006/42/EC and EN474.

AXLES

Front : Oscillating planetary drive axle, oscillating angle.	11,5°
Rear: Rigid planetary drive axle.	

STEERING

Fully hydraulically controlled front axle with integrated steering cylinder.	
Max. steering angle.	32°

SWING SYSTEM

Hydrostatic drive with 2-stage planetary gear and axial piston fixed displacement motor, also acts as wear-resistant brake. In addition, automatically controlled spring-loaded multi-disc brake acting as parking brake.	
Swing speed.	0-10 rpm

KNICKMATIK®

Lateral parallel adjustment of boom arrangement at full dig depth.	
Angle of articulation / lateral adjustment left.	53° / 870 mm
Angle of articulation / lateral adjustment right.	67° / 990 mm

ELECTRICAL SYSTEM

Nominal voltage.	12V
Battery.	12V / 135 Ah
Generator.	14V / 95 Ah
Starter.	112V / 4,0 kW

FLUID CAPACITIES

Fuel tank.	160 l
AdBlue tank.	10 l
Hydraulic system (incl. Tank 60 l).	175 l

BRAKES

Service brake: Hydraulic pump accumulator two-circuit brake, acting on oil-immersed multi-disc brakes of front and rear axle.
Excavator brake: Acting on front and rear axle due to lockable service brake.
Auxiliary brake: Hydrostatic travel drive in closed circuit acting as non-wearing auxiliary brake.
Parking brake: Hydraulic spring-loaded brake, electrically actuated.

TIRES

Standard 8.25-20, 12 PR twin tires.

MAINTENANCE FREQUENCY

Change engine oil and filter:	500h or minimum once a year.
Change fuel filter:	1 000h or minimum once a year
Change hydraulic oil:	check at 100 + 500h; every 1 000h or minimum every 2 years.
Change hydraulic oil filter:	first after 100h, then follow the instructions at display.
Change cooling fluid:	if needed or minimum every 2 years.