



We build a better future

Robex

210LC-9

Equipped with Tier 3 Engine



*Photo may include optional equipment.



Specifications

ENGINE

MODEL		CUMMINS QSB6.7	
Type		Water cooled, 4 cycle Diesel, 6-Cylinders in line, direct injection, turbocharged, charged air cooled and low emission	
Rated flywheel horse power	SAE	J1995 (gross)	151 HP (113 kW) / 1,900 rpm
		J1349 (net)	143 HP (107 kW) / 1,900 rpm
	DIN	6271/1 (gross)	153 PS (113 kW) / 1,900 rpm
		6271/1 (net)	145 PS (107 kW) / 1,900 rpm
Max. torque		63.6 kgf.m (460 lbf.ft) / 1,500 rpm	
Bore x stroke		107 x 124 mm (4.2" x 4.9")	
Piston displacement		6,700 cc (409 in ³)	
Batteries		2 x 12V x 100AH	
Starting motor		24 V - 4.5 kW	
Alternator		24 V - 50 Amp	

HYDRAULIC SYSTEM

MAIN PUMP	
Type	Two variable displacement axial piston pumps
Max. flow	2 X 222 l/min (58.6 US gpm / 48.8 UK gpm)
Sub-pump for pilot circuit	Gear pump

Cross-sensing and fuel saving pump system

HYDRAULIC MOTORS

Travel	Two speed axial piston motor with brake valve and parking brake
Swing	Axial piston motor with automatic brake

RELIEF VALVE SETTING

Implement circuits	350 kgf/cm ² (4,978 psi)
Travel	350 kgf/cm ² (4,978 psi)
Power boost (boom, arm, bucket)	380 kgf/cm ² (5,404 psi)
Swing circuit	265 kgf/cm ² (3,769 psi)
Pilot circuit	40 kgf/cm ² (568 psi)
Service valve	Installed

HYDRAULIC CYLINDERS

No. of cylinder-bore x stroke	Boom : 2 - 120 x 1,290 mm (4.7" x 50.8")
	Arm : 1 - 140 x 1,510 mm (5.5" x 59.4")
	Bucket : 1 - 120 x 1,055 mm (4.7" x 41.5")

DRIVES & BRAKES

Drive method	Fully hydrostatic type
Drive motor	Axial piston motor, in-shoe design
Reduction system	Planetary reduction gear
Max. drawbar pull	21,100 kgf (46,500lbf)
Max. travel speed (high) / (low)	5.3 km/hr (3.3 mph) / 3.4 km/hr (2.1 mph)
Gradeability	35° (70 %)
Parking brake	Multi wet disc

CONTROL

Pilot pressure operated joysticks and pedals with detachable lever provide almost effortless and fatigueless operation.

Pilot control	Two joysticks with one safety lever (LH): Swing and arm (RH): Boom and bucket (ISO)
Traveling and steering	Two levers with pedals
Engine throttle	Electric, Dial type
Lights	Two lights mounted on the boom, one light mounted in the battery box

SWING SYSTEM

Swing motor	Axial piston motor
Swing reduction	Planetary gear reduction
Swing bearing lubrication	Grease-bathed
Swing brake	Multi wet disc
Swing speed	12 rpm

COOLANT & LUBRICANT CAPACITY

Refilling	liter	UK gal
Fuel tank	400	88.0
Engine coolant	35	7.7
Engine oil	24	5.3
Swing device - gear oil	5	1.1
Final drive (each) - gear oil	5.8	1
Hydraulic system (including tank)	290	63.8
Hydraulic tank	160	35.2

UNDERCARRIAGE

The X-leg type center frame is integrally welded with reinforced box-section track frames. The undercarriage includes lubricated rollers, idlers, track adjusters with shock absorbing springs and sprockets, and a track chain with double or triple grouser shoes.

Center frame	X - leg type
Track frame	Pentagonal box type
No. of shoes on each side	49
No. of carrier rollers on each side	2
No. of track rollers on each side	9
No. of rail guards on each side	2

OPERATING WEIGHT

Operating weight, including 5,680 mm (18' 8") boom, 2,920 mm (9' 7") arm, SAE heaped 0.92 m³ (1.20 yd³) bucket, lubricant, coolant, full fuel tank, full hydraulic tank, and all standard equipments.

MAJOR COMPONENT WEIGHT

Upperstructure	5,850 kg (12,900 lb)
Counterweight	3,800 kg (8,380 lb)
Boom (with arm cylinder)	1,950 kg (4,300 lb)
Arm (with bucket cylinder)	1,095 kg (2,410 lb)

OPERATING WEIGHT

Shoes			Operating weight kg (lb)	Ground pressure kgf/cm ² (psi)
Type	Width mm (in)			
Triple grouser	600 (24")	R210LC-9	21,900 (48,280)	0.46 (6.54)
		R210LC-9 H/W	23,360 (51,500)	0.50 (7.11)
		R210LC-9 L/R	23,835 (52,547)	0.51 (7.25)
	700 (28")	R210LC-9	22,250 (49,050)	0.40 (5.69)
		R210LC-9 H/W	23,710 (52,270)	0.43 (6.11)
		R210LC-9 L/R	24,185 (53,319)	0.43 (6.11)
	800 (32")	R210LC-9	22,515 (49,640)	0.36 (5.12)
		R210LC-9 H/W	23,975 (52,855)	0.38 (5.40)
		R210LC-9 L/R	24,450 (53,903)	0.39 (5.55)
	900 (36")	R210LC-9	22,760 (50,180)	0.32 (4.55)
		R210LC-9 L/R	24,715 (54,487)	0.35 (4.98)
	Double grouser	710 (28")	R210LC-9 H/W	24,135 (53,210)

Dimensions & Working Ranges

DIMENSIONS R210LC-9

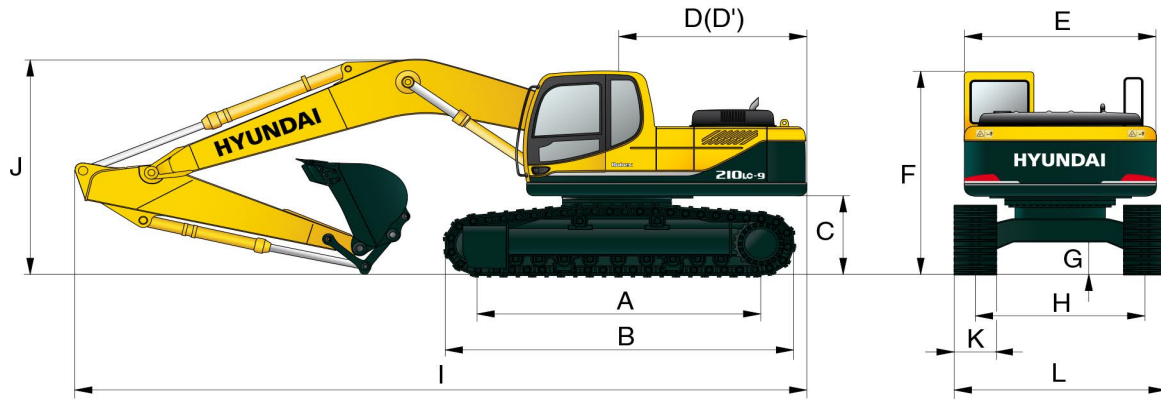

	mm (ft · in)		mm (ft · in)
A Tumbler distance	3,650 (12' 0")	Boom length	5,680 (18' 8")
B Overall length of crawler	4,440 (14' 7")	Arm length	2,400 (7' 10")
C Ground clearance of counterweight	1,060 (3' 6")	I Overall length	9,570 (31' 5")
D Tail swing radius	2,840 (9' 4")	J Overall height of boom	3,110 (10' 2")
D' Rear-end length	2,770 (9' 1")	K Track shoe width	700 (28")
E Overall width of upperstructure	2,740 (9' 0")	L Overall width	3,090 (10' 2")
F Overall height of cab	2,920 (9' 7")		
G Min. ground clearance	480 (1' 7")		
H Track gauge	2,390 (7' 10")		

WORKING RANGES R210LC-9

mm (ft · in)

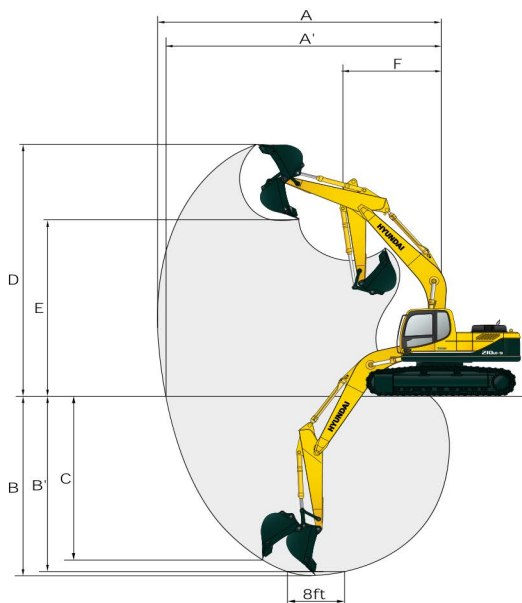

Boom length	5,680 (18' 8")
Arm length	2,400 (7' 10")
A Max. digging reach	9,500 (31' 2")
A' Max. digging reach on ground	9,330 (30' 7")
B Max. digging depth	6,220 (20' 5")
B' Max. digging depth (8° level)	6,010 (19' 9")
C Max. vertical wall digging depth	5,720 (18' 9")
D Max. digging height	9,340 (30' 8")
E Max. dumping height	6,520 (21' 5")
F Min. front swing radius	3,740 (12' 3")



Lifting Capacities

R210LC-9 HIGH WALKER

Rating over-front Rating over-side or 360 degrees

Boom : 5.68 m (18' 8") / Arm : 2.4 m (7' 10") / Bucket : 0.92 m³ (1.20 yd³) SAE heaped / Shoe : 800 mm (32") triple grouser with 3,800 kg (8,380 lb) Counterweight

Load point height m (ft)		Load radius										At max. reach		
		1.5 m (5.0 ft)		3.0 m (10.0 ft)		4.5 m (15.0 ft)		6.0 m (20.0 ft)		7.5 m (25.0 ft)		Capacity	Reach	
														m (ft)
7.5 m (25.0 ft)	kg lb											*3700 *8160	*3700 *8160	7.31 (24.0)
6.0 m (20.0 ft)	kg lb							*4050 *8930	*4050 *8930			*3790 *8360	3570 7870	8.30 (27.2)
4.5 m (15.0 ft)	kg lb					*5360 *11820	*5360 *11820	*4580 *10100	*4580 *10100	*4260 *9390	4130 9110	*3920 *8640	3110 6860	8.87 (29.1)
3.0 m (10.0 ft)	kg lb					*7130 *15720	*7130 *15720	*5390 *11880	*5390 *11880	*4610 *10160	4010 8840	*4080 *8990	2890 6370	9.12 (29.9)
1.5 m (5.0 ft)	kg lb					*8720 *19220	8580 18920	*6220 *13710	5500 12130	*5020 *11070	3870 8530	4110 9060	2860 6310	9.08 (29.8)
Ground Line	kg lb			*9350 *20610	*9350 *20610	*9550 *21050	8290 18280	*6790 *14970	5310 11710	*5320 *11730	3780 8330	4340 9570	3020 6660	8.75 (28.7)
-1.5 m (-5.0 ft)	kg lb	*10290 *22690	*10290 *22690	*14180 *31260	*14180 *31260	*9620 *21210	8230 18140	*6950 *15320	5240 11550			*4650 *10250	3450 7610	8.07 (26.5)
-3.0 m (-10.0 ft)	kg lb	*14760 *32540	*14760 *32540	*12990 *28640	*12990 *28640	*8950 *19730	8330 18360	*6470 *14260	5310 11710			*4690 *10340	4470 9850	6.94 (22.8)
-4.5 m (-15.0 ft)	kg lb			*10150 *22380	*10150 *22380	*7020 *15480	*7020 *15480							

- Lifting capacity is based on SAE J1097, ISO 10567.
- Lifting capacity of the Robex Series does not exceed 75% of the tipping load with the machine on firm, level ground or 87% of full hydraulic capacity.
- The load point is a hook located on the back of the bucket.
- (*) indicates the load limited by hydraulic capacity.



STANDARD EQUIPMENT

ISO Standard cabin

All-weather steel cab with 360° visibility
 Safety glass windows
 Rise-up type windshield wiper
 Sliding fold-in front window
 Sliding side window
 One key fits all lockable doors
 Hot & cool box
 Storage compartment & Ashtray
 Transparent cabin roof-cover
 Radio / MP3 Player with remote control and USB-input
 Handsfree mobile phone system with USB-charging device
 Sun visor

Computer aided power optimization (New CAPO) system

3-power modes, 3-work modes, User mode
 Auto & one-touch deceleration system
 Auto warm-up system
 Overheat prevention system

Self-diagnostics system

Automatic climate control

Air conditioner & heater
 Defroster

Starting Aid (air grid heater) for cold weather

Centralized monitoring

LCD display
 Engine speed or Trip meter
 Clock
 Gauges
 Fuel level gauge
 Engine coolant temperature gauge
 Hyd. oil temperature gauge
 Warning lamps
 Engine warning
 Overload
 Communication error
 Low battery
 Air filter clogging
 Indicators
 Max power
 Low speed/High speed
 Fuel warmer
 Auto deceleration

Door and cab locks, one key fits all

Two outside rearview mirrors

Fully adjustable suspension seat with seat belt

Adjustable joysticks

Console box height adjust system

Four frontal working lights

Electric horn

Batteries (2 x 12V x 100 AH)

Battery master switch

Removable clean-out screen for cooler

Automatic swing brake

Removable reservoir tank

Fuel pre-filter with fuel warmer

Boom holding system

Arm holding system

Counterweight (3,800 kg; 8,380 lb)

Track shoes (600 mm; 24")

Track rail guard

Viscous fan clutch

Accumulator for lowering work equipment

Lower frame under cover (normal)

* Standard and optional equipment may vary. Contact your Hyundai dealer for more information. The machine may vary according to international standards.

* The photos may include attachments and optional equipment that are not available in your area.

* Materials and specifications are subject to change without advance notice.

* All imperial measurements rounded off to the nearest pound or inch.

PLEASE CONTACT



Hyundai Heavy Industries Europe N.V.

VOSSENDAAL 11, 2440 GEEL, BELGIUM TEL: (32) 14-56-2200 FAX: (32) 14-59-3405